

TQMa6ULx

Energy efficient for future designs

The Minimodule TQMa6ULx, based on the i.MX6UL from NXP, combines the ARM Cortex-A7 core technology with a variety of interfaces. The integrated graphics controller supports applications with display and touch screen requirements. For various applications such as, industrial automation and controls with requirements for low power and secure data processing, there are three CPU variants available. With a Single Cortex™-A7 core and a clock rate up to 528 MHz the TQMa6ULx provides a balanced ratio between applications for visualization and control performance and power dissipation.

The highlights:

- Graphic
- Extended temperature range
- 2x Ethernet with IEEE1588
- Low power consumption (typ. 1 W)
- Camera Sensor Interface
- Security functions
- Long term availability

Block Diagram TQMa6ULx

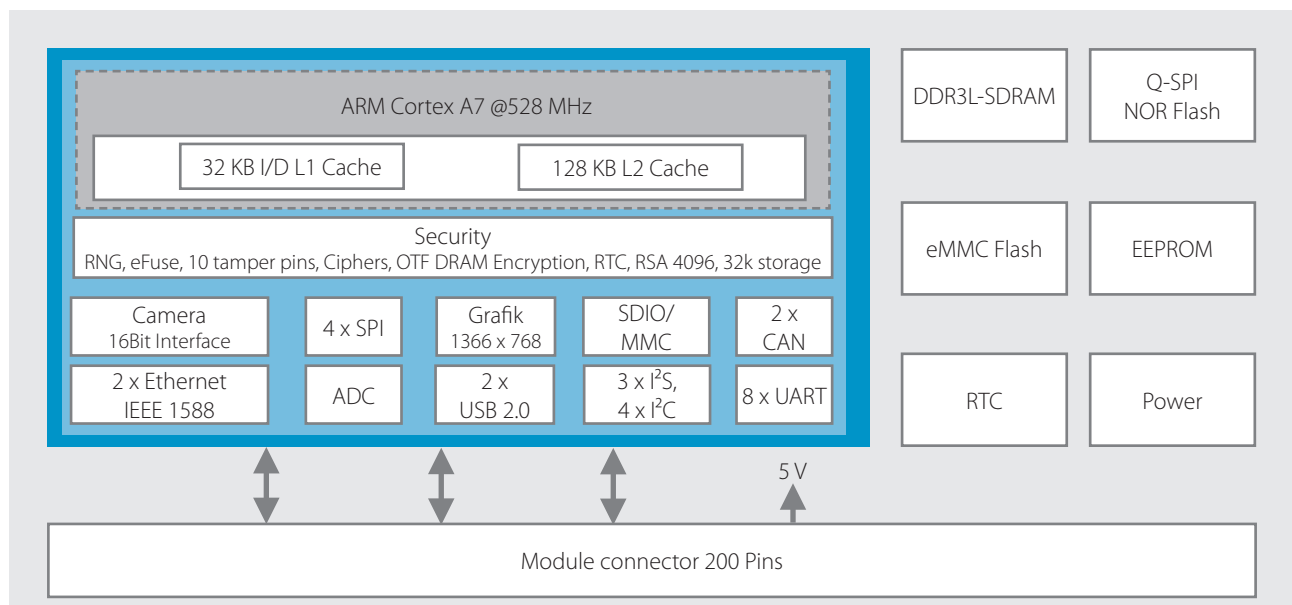

Technical specification

Microprocessor

i.MX6UL-1, i.MX6UL-2, i.MX6UL-3

System interfaces

Up to 2x Ethernet 10/100 Mbit

Up to 2x CAN

Up to 2x USB 2.0 high speed OTG interface

Up to 8x UART

Periphery interfaces

Up to 2x SDIO/MMC

Up to 4x I²C

Up to 4x SPI

Up to 3x I²S

Graphic

LCD Interface (24 Bit RGB)

1 x 16 Bit Camera Sensor Interface

Memory

DDR3L-SDRAM: Up to 1 GB

Quad SPI NOR: Up to 256 MB

Up to 32 GB eMMC-Flash

EEPROM: 0 / 64 kbit

Other

Real Time Clock (RTC)

Temperature sensor

CPU JTAG Interface

Power supply

5 V

Ambient conditions

Standard temperature range: -25°C...+85°C

Extended temperature range: -40°C...+85°C

Dimensions

46 mm x 32 mm

Plug-in system

Board-to-board plug-in system 200 pins

Operating systems

Linux

Operating systems on request

VxWorks, QNX, WIN EC 2013

Ordering information

TQMa6UL1-AA

TQMa6UL1, Cortex-A7 / 528 MHz, 4 GB eMMC Flash
256MB DDR3L, 64 kB EEPROM, -25°C ...+85°C

TQMa6UL2-AA

TQMa6UL2, Cortex-A7 / 528 MHz, 4 GB eMMC Flash
256MB DDR3L, 64 kB EEPROM, -25°C ...+85°C

TQMa6UL3-AA

TQMa6UL3, Cortex-A7 / 528 MHz, 4 GB eMMC Flash
256 MB DDR3L, 64 kB EEPROM, -25°C ...+85°C

STKa6ULx-AA

STKa6 (Eval Kit) with TQMa6ULx-AA, Cortex-A7 / 528 MHz, 256 MB DDR3L, 4 GB eMMC Flash,
64 kB EEPROM, 1x RS232, 1x RS485, 2 x CAN 2.0B separated
3x USB 2.0 HOST, 1x USB 2.0 OTG, 2x ETH 10/100,
LCD Port, 1xHDMI, LVDS, 1x Mini PCIe (only USB), RTC,
Temperature sensor, Reset-Button, SD interface,
Power supply, 4 GB SD card, Cables

Starter kit STKa6ULx set

The core of the STKa6ULx set is the TQMa6ULx module with a Cortex-A7 CPU. The components contained in the starter kit constitute a modular system enabling you to develop your own product ideas. Development of graphic interfaces can be started immediately using the prepared combination of closed display unit and starter kit that are matched to each other. To develop your own hardware you can use the certified and qualified circuit components of the starter kit in your own designs.

TQ-Systems GmbH

Mühlstr. 2 | Gut Delling | 82229 Seefeld | Germany

Phone: +49 8153 9308-0 | Fax: +49 8153 4223

info@tq-group.com | www.tq-group.com

>> Quicklink: www.tq-group.com/en/TQMa6ULx

Technology in Quality

