

# XPedite7201

Intel® Atom™ Processor-Based Conduction- or Air-Cooled PMC/XMC Module

- ▶ Intel® Atom™ processor at up to 1.6 GHz
- ▶ Conduction- or air-cooled PMC/XMC module
- ▶ 1 GB of DDR2-533 SDRAM
- ▶ Up to 4 GB of NAND flash
- ▶ x1 PCI Express XMC interface
- ▶ 32-bit, 66-MHz PCI PMC interface
- ▶ Gigabit Ethernet port with integrated magnetics
- ▶ Four USB 2.0 high-speed ports
- ▶ Two RS-232/RS-422/RS-485 serial ports
- ▶ Dual DVI-D video
- ▶ Audio line-in/out
- ▶ Linux LSP
- ▶ VxWorks BSP
- ▶ QNX Neutrino BSP
- ▶ Green Hills INTEGRITY BSP
- ▶ Microsoft Windows XP/Vista drivers

## XPedite7201

The XPedite7201 is a high-performance, low-power, conduction- or air-cooled PMC/XMC module based on the Intel® Atom™ processor. With an x1 PCI Express or 32-bit, 66-MHz PCI interconnect and a Gigabit Ethernet port, the XPedite7201 is ideal for high-bandwidth data-processing applications.

The XPedite7201 accommodates 1 GB of DDR2-533 SDRAM to support memory-intensive applications and hosts numerous I/O ports including Gigabit Ethernet, USB 2.0, IDE, RS-232/RS-422/RS-485, and dual DVI video.

Wind River VxWorks, QNX Neutrino, and Green Hills INTEGRITY Board Support Packages (BSPs) are available for the XPedite7201, as well as a Linux 2.6 LSP and Windows drivers. The XPedite7201 also features a UEFI system firmware.



Extreme Engineering Solutions

*...Always Fast*

### Extreme Engineering Solutions

3225 Deming Way, Suite 120 • Middleton, WI 53562  
Phone: 608.833.1155 • Fax: 608.827.6171  
sales@xes-inc.com • <http://www.xes-inc.com>

**Processor**

- Intel® Atom™ processor at up to 1.6 GHz

**Memory**

- One channel of up to 1 GB of DDR2-533 SDRAM
- Up to 4 GB of NAND flash

**PMC/XMC Interface**

- 32-bit, 66-MHz PCI bus (PMC interface)
- x1 PCIe port (XMC interface)

**P14 I/O**

- Single DVI video
- Two USB 2.0 ports
- Two RS-232/RS-422/RS-485 ports
- One 10/100/1000Base-T Ethernet port
- Audio I/O

**P16 I/O**

- Dual DVI video
- One 10/100/1000Base-T Ethernet port
- Two RS-232/RS-422/RS-485 ports
- Two USB 2.0 ports
- Audio I/O

**Software Support**

- Linux LSP
- Wind River VxWorks BSP
- QNX Neutrino BSP
- Green Hills INTEGRITY BSP
- Windows drivers

**Physical Characteristics**

- PMC/XMC conduction-cooled form factor
- Dimensions: 149 mm x 74 mm, 10-mm stacking height

**Environmental Requirements**

Contact factory for appropriate board configuration based on environmental requirements.

- Supported ruggedization levels (see chart below): Level 1, Level 2, Level 3, Level 4, Level 5
- Humidity: 0% to 95% non-condensing

**Power Requirements**

- Estimated maximum power consumption: 7 W

Ruggedization Level	Level 1	Level 2	Level 3	Level 4	Level 5
Cooling Method	Standard Air-Cooled	Extended Air-Cooled	Rugged Air-Cooled	Conduction-Cooled	Conduction-Cooled
Operating Temperature	0 to +55 °C	0 to +65 °C	-40 to +70 °C	-40 to +70 °C	-40 to +85 °C
Vibration	0.002 g <sup>2</sup> /Hz	0.002 g <sup>2</sup> /Hz	0.04 g <sup>2</sup> /Hz	0.1 g <sup>2</sup> /Hz	0.1 g <sup>2</sup> /Hz
Shock	20 g	20 g	40 g	40 g	40 g
Storage Temperature	-40 to +105 °C	-40 to +105 °C	-55 to +105 °C	-55 to +105 °C	-55 to +105 °C

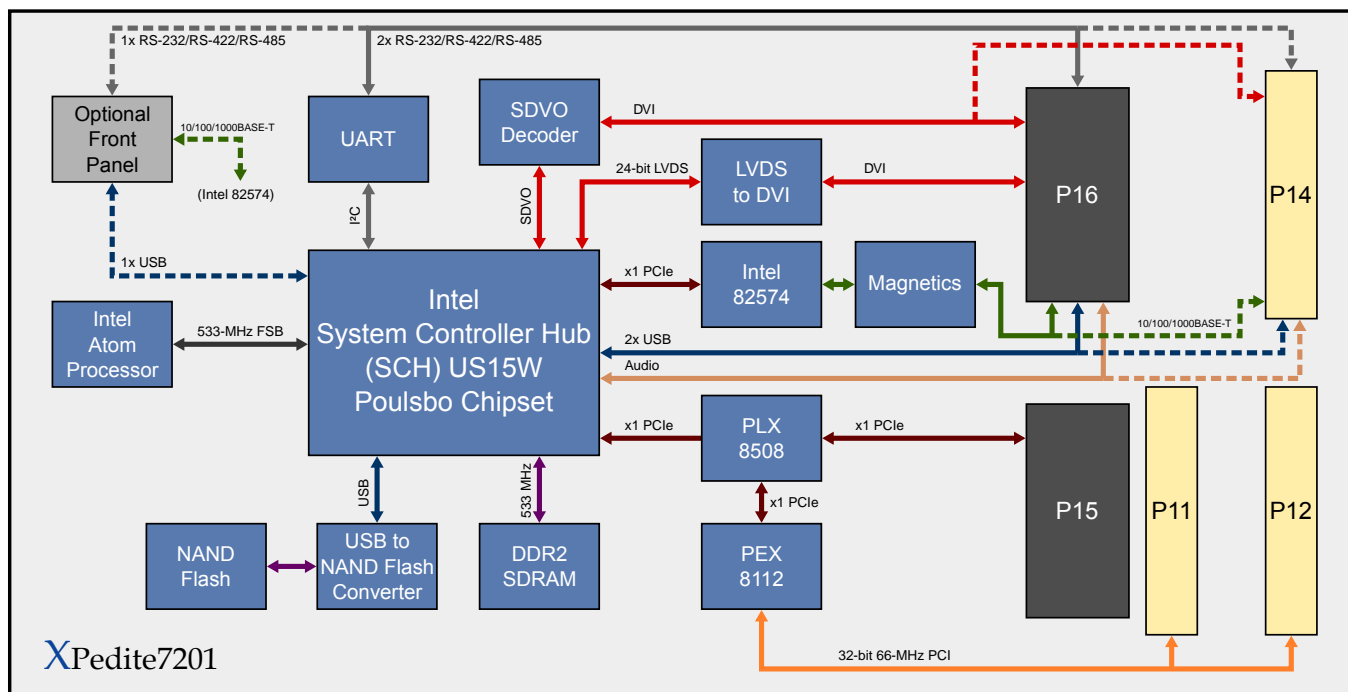

Distributor: **NeoMore** 23 rue des Poiriers F-78370 PLAISIR FRANCE +33 1 30 64 15 81 [www.neomore.com](http://www.neomore.com)

